

XS-5-4225-Z150 (4200x2500xZ1500五轴加工中心)

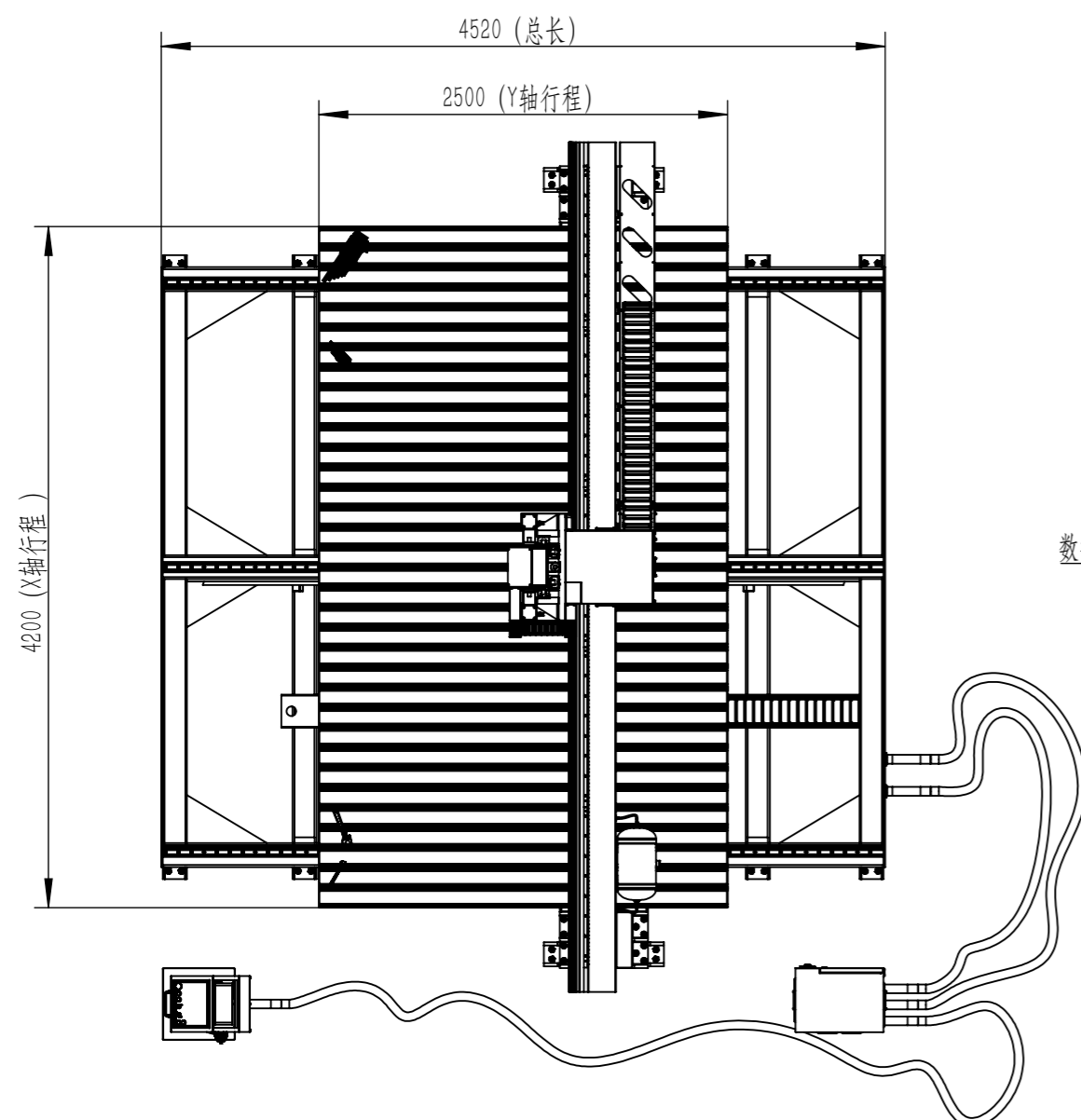

xs5c.com

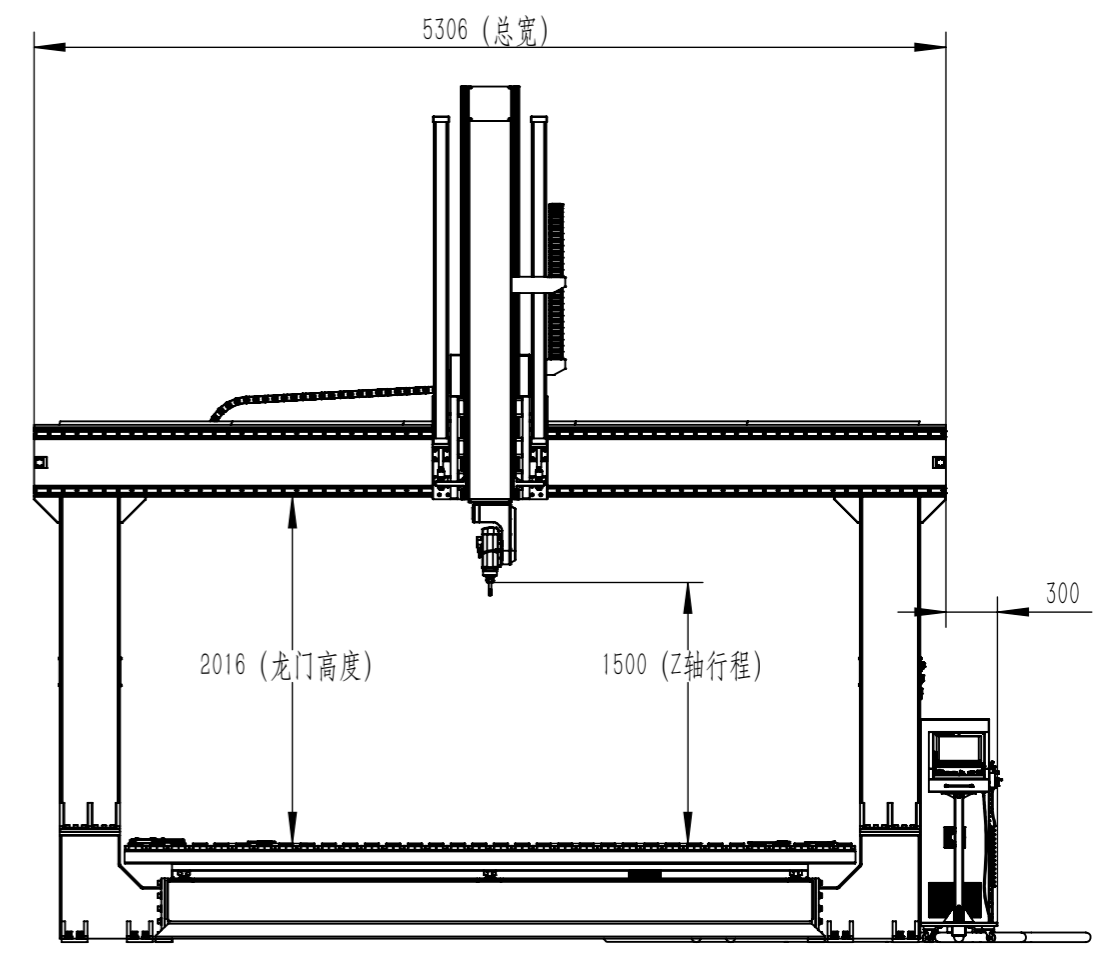
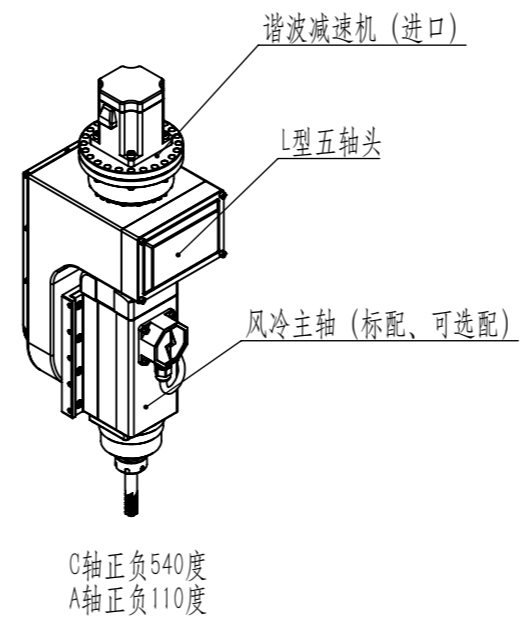
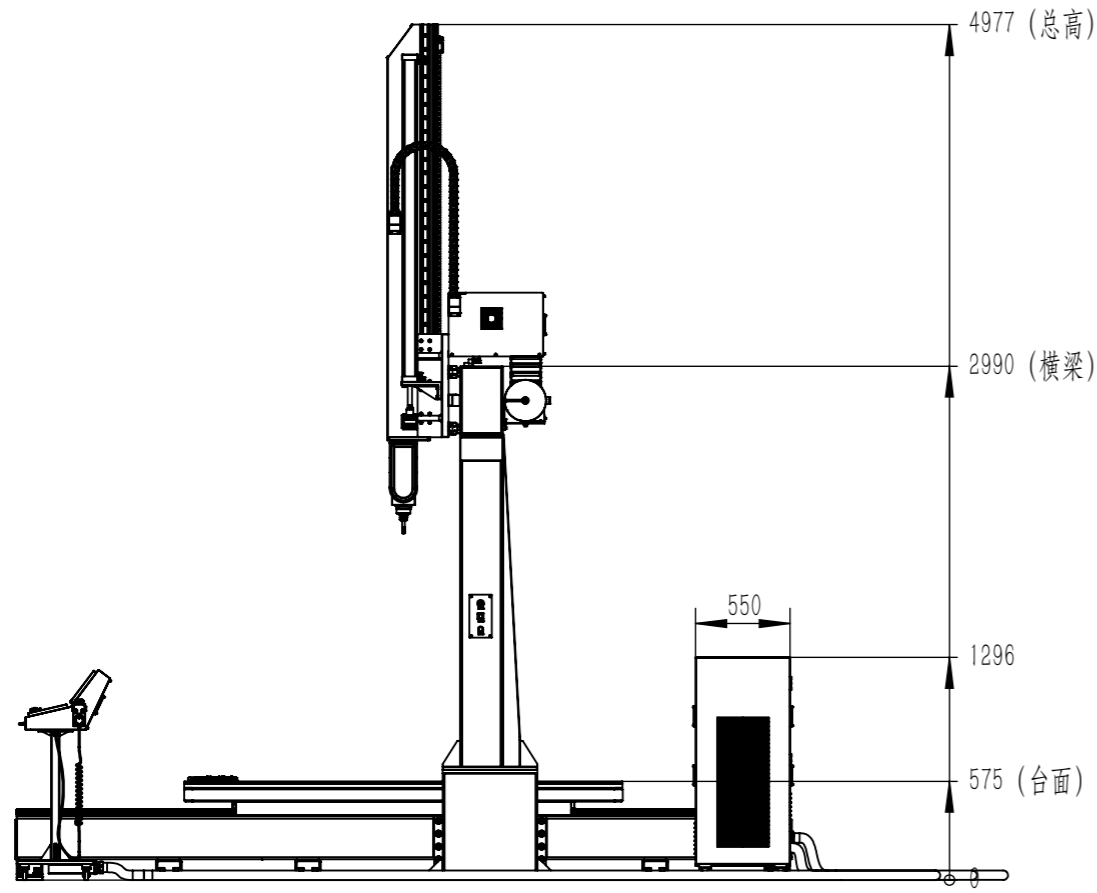
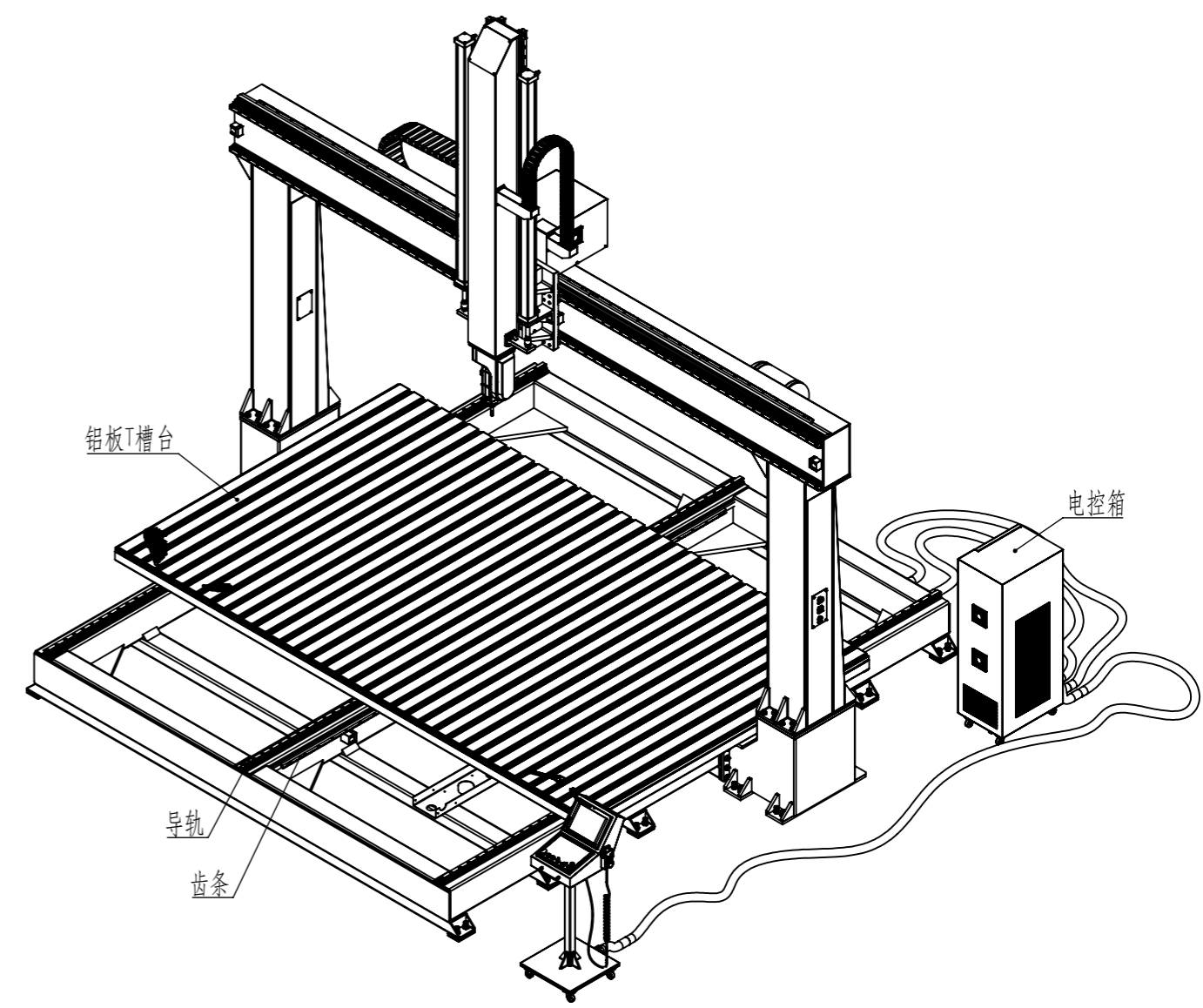
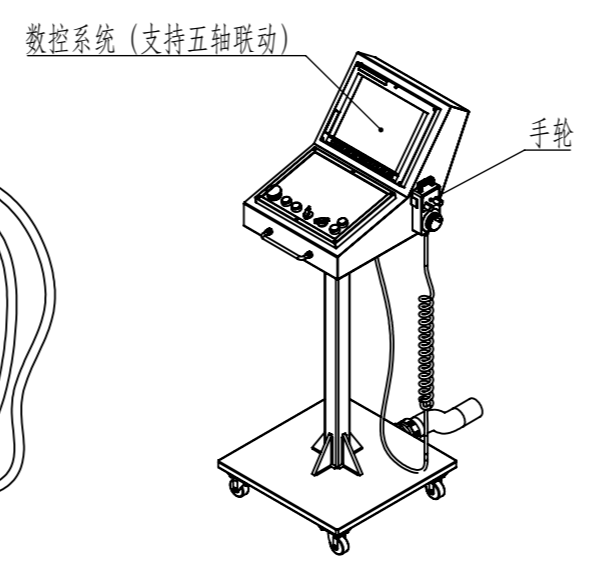

注意：本图纸所注尺寸可能因设备更新或客户定制而有所不同，图纸与实物可能存在些许差异

【本机需拆成零件运输到客户厂房内再安装】